

SALEM



Application

Specially designed for those cases where skyward light emission is not permitted.

For illuminating roads and walkways in residential areas, pedestrianised streets, parks and gardens, plazas, etc. Recommended height for mounting is between 3 and 5m.

Technical specification

Decorative street lamp, manufactured in die-cast aluminium, with a built-in reflector and flat glass horizontal lens, designed to fulfil the strictest requirements for limiting light emissions towards the upper hemisphere in urban and residential environments.

For high pressure sodium and metal halide lamps up to 150 W.

Housing

Housing in two parts (canopy and lower body) in die-cast aluminium, electrostatically sprayed with a polyester powder paint finish, following anti-corrosion priming, and oven cured at 180°C.

Electrical unit mounted in the canopy, on a removable tray. Top adornment is removable for substituting with an external photoelectric control unit, supplied separately.

Standard colour: RAL 9011 black. Consult other colour options.

Optical assembly

Faceted aluminium reflector with an EPDM gasket for perfect seal with the glass lens. Various photometric distributions possible using simple device to adjust lampholder position. Flat tempered glass lens located horizontally, under the canopy. No side panels. Strict glare control. No side emission towards the upper hemisphere.

Installation

System for mounting to columns of up to 76mm diameter, by way of an adaptor built into the lower body.

Maintenance

Tool-less relamping, thanks to stainless steel latch.

Degree of protection: IP54.

Insulation: Class I.

Effective projected area: 0.10 m²

Approx. weight with ballast: 5 to 8kg.

Notes

The luminaires may incorporate a photoelectric control unit.



Dimensions (mm)

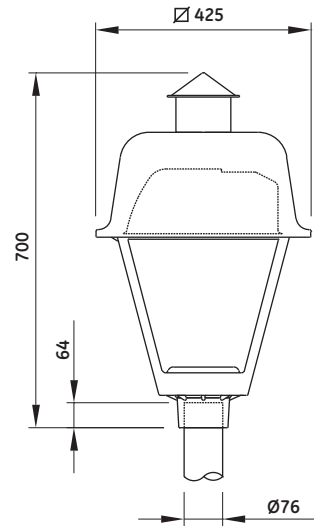

Photometric data

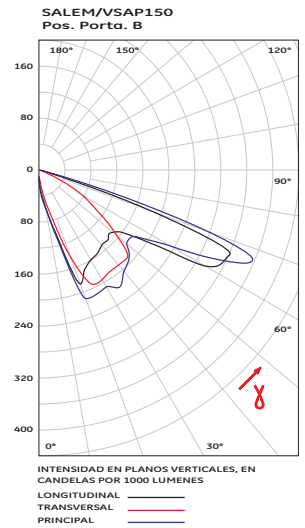

SALEM

CEI 34.21 /EN 60598-1, IEC 60 – 230V 50Hz – Class I (Optional Class II)
Optic IP54 – Control gear IP54

Description	Lamp ILCOS code	Pack Qty	Product Code
SALEM HPS 70W	SE-70-H-E27-72/156	1	88023
SALEM HPS 100W	ST-100-H-E40-48/211	1	88024
SALEM HPS 150W	ST-150-H-E40-48/211	1	88025
SALEM MH 150W E40	MT-150-H-E40-48/209	1	88026